

淡江大學 108 學年度日間部寒假轉學生招生考試試題

系別：土木工程學系三年級

科目：工程力學(含靜力學、材料力學)

0-1

考試日期：1月13日(星期一) 第1節

本試題共 5 大題， 3 頁

本試題雙面印刷

1. (20%) Determine the moment of inertia of the shaded area with respect to the x axis.

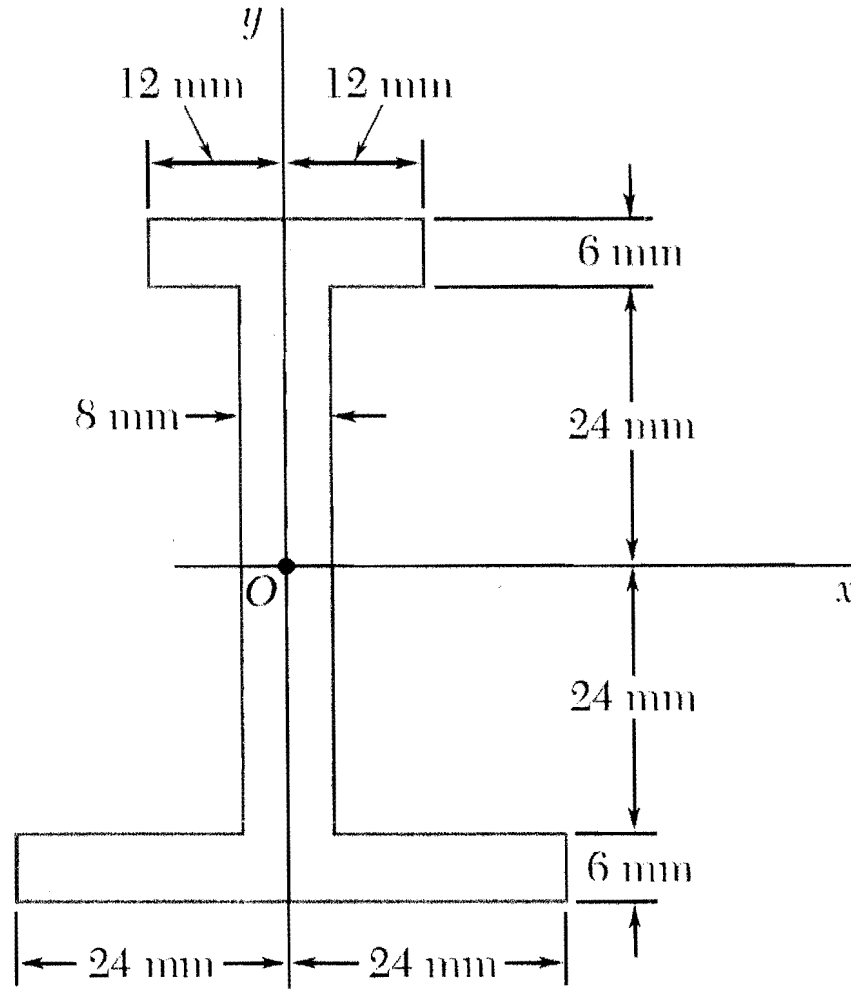

2. (20%) (a) Draw the shear and bending-moment diagrams for beam AB , (b) determine the magnitude and location of the maximum absolute value of the bending moment.

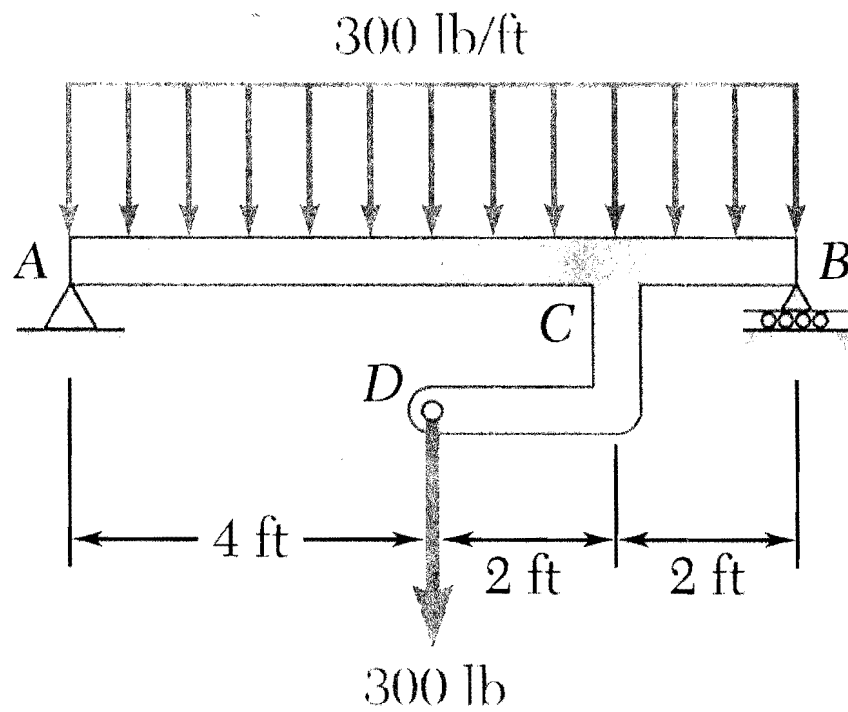

背面尚有試題

淡江大學 108 學年度日間部寒假轉學生招生考試試題

系別：土木工程學系三年級

科目：工程力學(含靜力學、材料力學)

10-2

考試日期：1月13日(星期一) 第1節

本試題共 5 大題， 3 頁

3. (20%) Using the method of joints, determine the force in each member of the truss shown. State whether each member is in tension or compression.

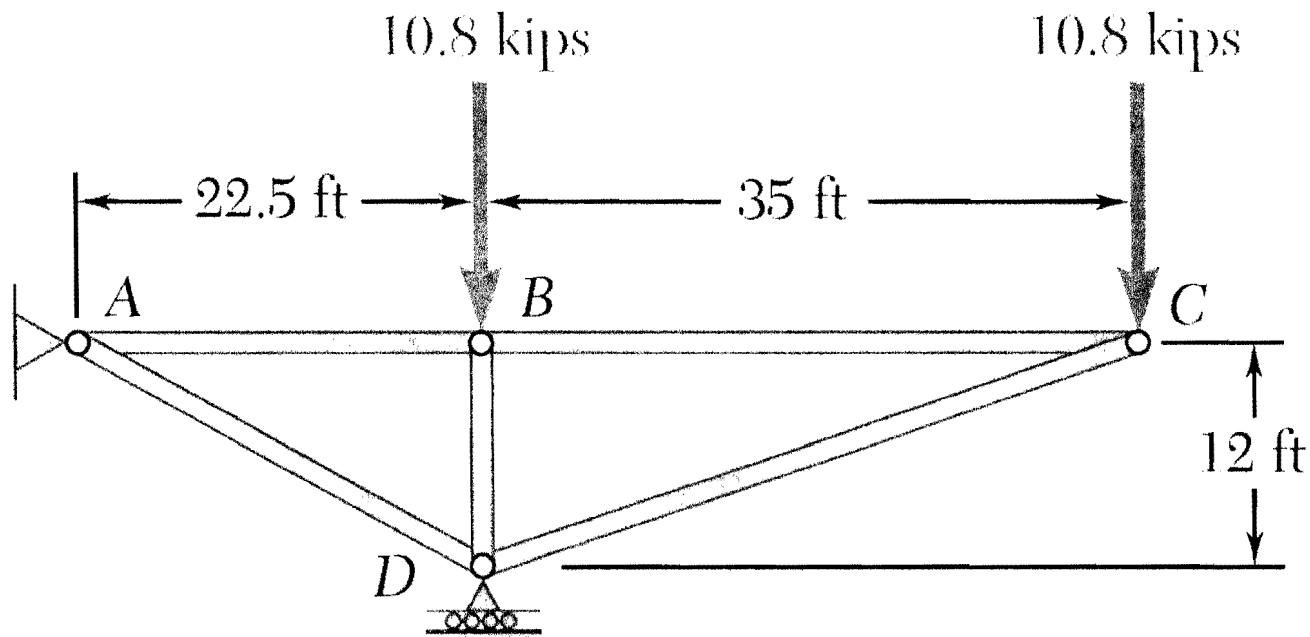

4. (20%) Determine the components of the forces acting on each member of the frame shown.

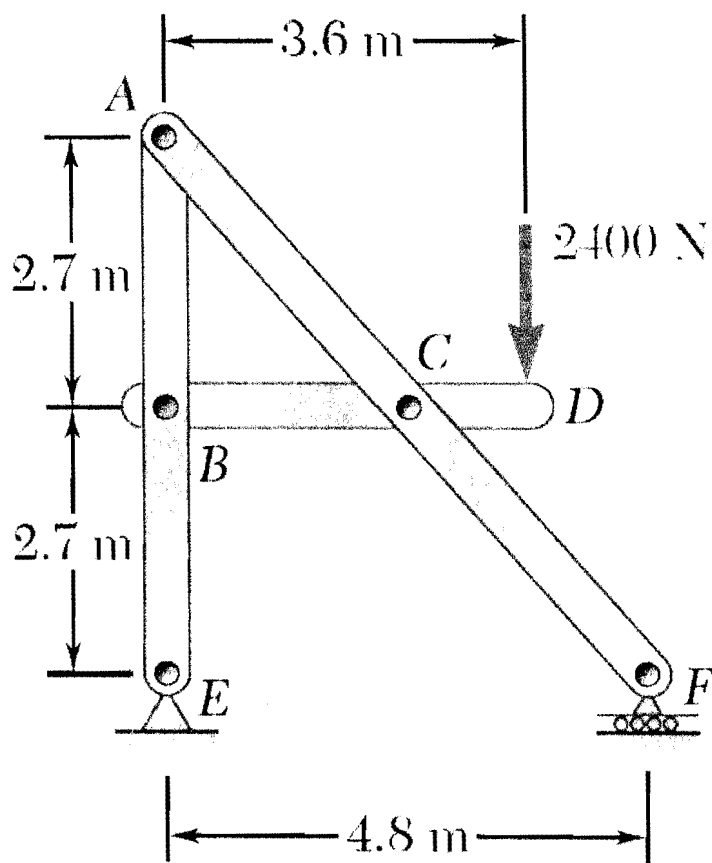

淡江大學 108 學年度日間部寒假轉學生招生考試試題

系別：土木工程學系三年級

科目：工程力學(含靜力學、材料力學)

10-3

考試日期：1月13日(星期一) 第1節

本試題共 5 大題， 3 頁

5. (20%) A stepped bar as shown. The diameters of the bar are $d_1=20$ cm, $d_2=40$ cm, and length $L = 10$ m. (assume linearly elastic behavior)
- (a) Determine the stress in segments AC and CB, σ_{AC} and σ_{BC} , when a downward load $P = 100$ N applied at point A.
- (b) Determine the displacement at point A and the strain energy, when a downward load $P = 100$ N applied at point A.
- (c) Determine the displacement at point A, consider the weight of the bar plus a downward load $P = 100$ N applied at point A. ($\gamma = 80$ kN/m³, $E = 200$ GPa)

