

淡江大學 107 學年度日間部寒假轉學生招生考試試題

系別：土木工程學系三年級

科目：工程力學(含靜力學、材料力學)

12-1

考試日期：1月13日(星期日) 第1節

本試題共 5 大題， 1 頁

1. Draw the shear-force and bending-moment diagrams for the beam shown in Fig. 1. 20%
2. Using the method of joints, determine the force in members BE and FE of the truss shown in Fig.2. ($P_1 = 10 \text{ kN}$, $P_2 = 20 \text{ kN}$) 20%
3. A beam of T-section is supported and loaded as shown in Fig. 3. Determine: 20%
 - (a) The maximum tensile stress in the beam
 - (b) The maximum compressive stress in the beam
 - (c) The maximum shear stress in the web
4. A stepped shaft ABCD consisting of solid circular segments is subjected to three torque as shown in Fig. 4. The material is steel with shear modulus of elasticity $G = 80 \text{ Gpa}$. Calculate: 20%
 - (a) The maximum shear stress in the shaft
 - (b) The angle of twist ϕ_D (in degree) at end D.
5. Use the moment-area method to find the deflection δ_B at the free end B of the beam shown in Fig. 5 due to a uniform load of intensity q over the entire beam. (flexural rigidity $EI_1 = EI$ on BC, and flexural rigidity $EI_2 = 2EI$ on section AC) 20%

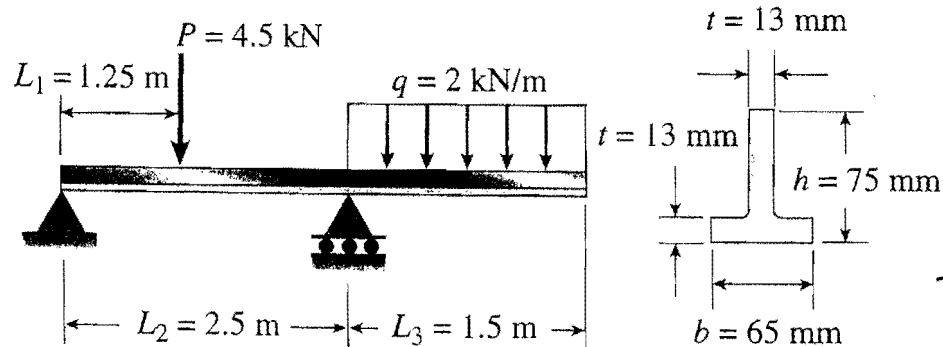
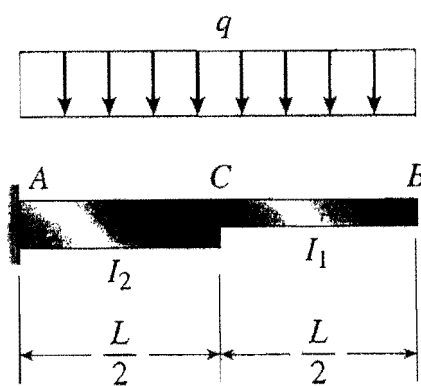
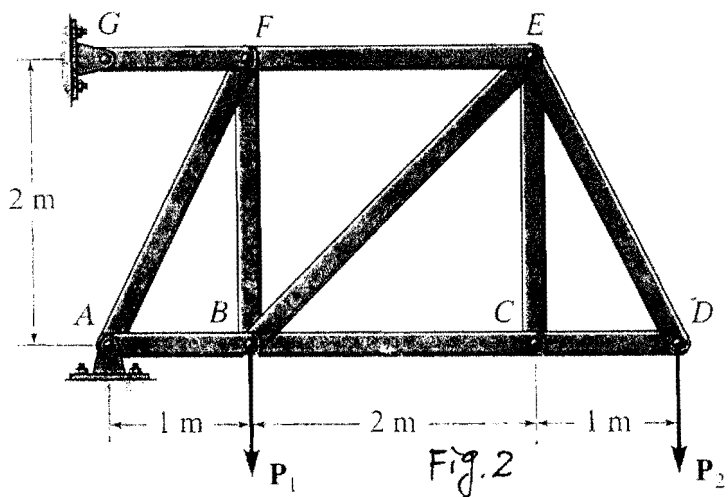
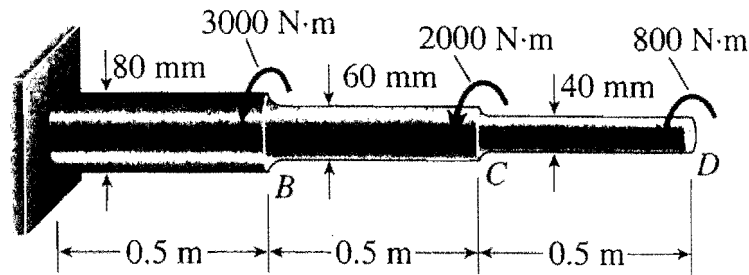
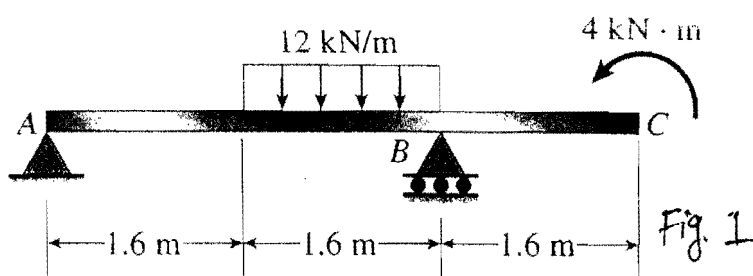

Fig. 3

Fig. 5