

淡江大學 97 學年度轉學生招生考試試題

49

系列：航空太空工程學系三年級

科目：工程力學(含靜力學、動力學)

可否使用計算機		
可	✓	否

本試題共 4 大題， 2 頁

1. The space shuttle launches an 800-kg satellite by ejecting it from the cargo bay as shown in Fig. 1. The ejection mechanism is activated and is in contact with the satellite for 3s to give it a velocity of 0.4 m/s in the z-direction relative to the shuttle. The mass of the shuttle is 100Mg. Determine the component of velocity v_z of the shuttle in the minus z-direction resulting from the ejection. Also find the time average F_{av} of the ejection force. (25%)

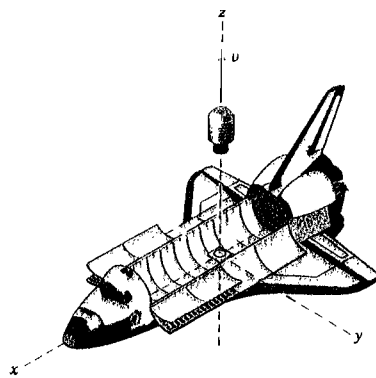

Fig. 1

2. Slide A moves in the horizontal slot with a constant speed v for a short interval of motion as shown in Fig. 2. Determine the angular velocity ω of bar AB in terms of the displacement x_A . (25%)

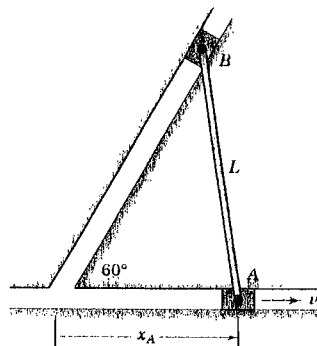

Fig. 2

本試題雙面印製

系別：航空太空工程學系三年級

科目：工程力學(含靜力學、動力學)

可否使用計算機		
可	✓	否

本試題共 4 大題， 2 頁

3. The cable shown in Fig. 3 has a mass of 1.2kg per meter of length and supports the pulley and lifting hook, which together have a mass of 5.0kg. Determine the force P necessary to maintain equilibrium. (25%)

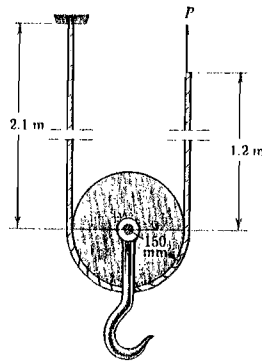

Fig. 3

4. The beam ABC shown in Fig. 4 is simply supported at A and B and has an overhang from B to C . The loads consist of a horizontal force $P_1 = 400$ lb acting at the end of the vertical arm and a vertical force $P_2 = 900$ lb acting at the end of the overhang. Draw the shear-force and bending-moment diagrams for this beam. (Note: Disregard the widths of the beam and vertical arm and use centerline dimensions when making calculations.) (25%)

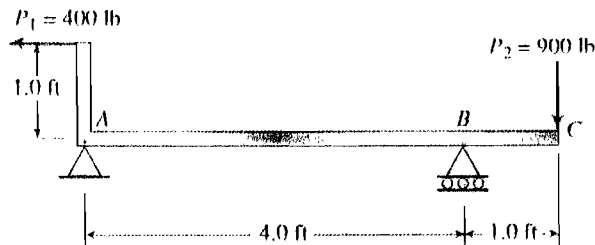

Fig. 4