

淡江大學八十八學年度日間部轉學生招生考試試題

40

系別：機械工程學系三年級

科目：工程力學

(包括靜力學、動力學、材料力學)

本試題共

五

頁

1. The static coefficients of friction are 0.1 for all (20%) contacting surfaces. Determine the force P required to initiate movement of the blocks A and B .

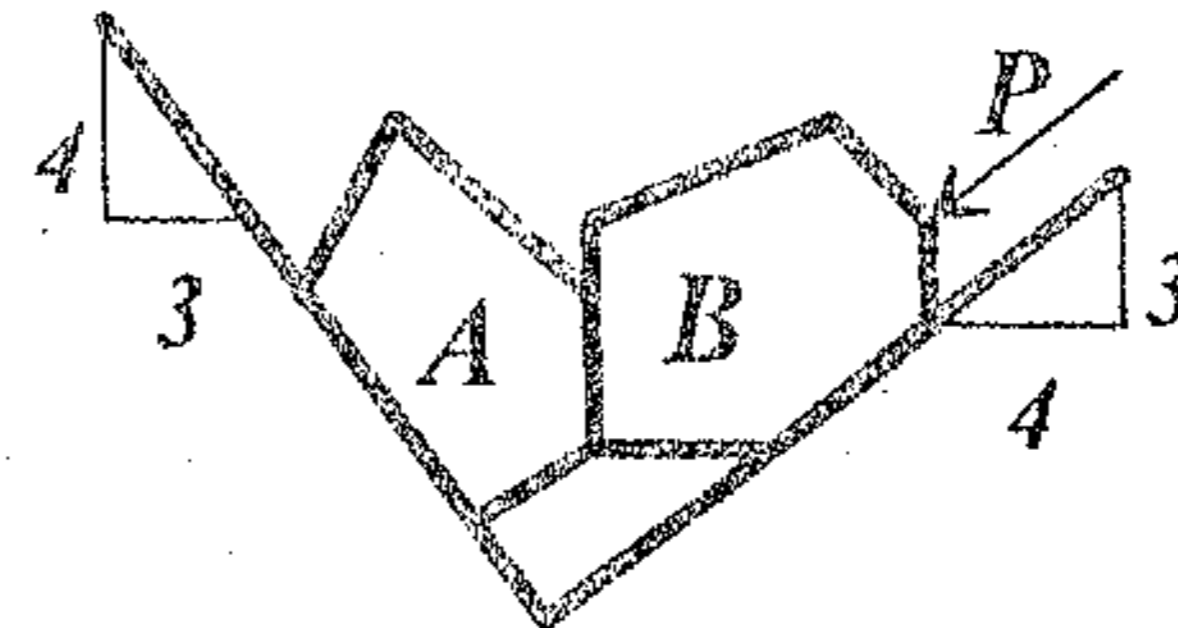

Figure 1

2. A collar A having a mass of 5 Kg can slide without (20%) friction on a pipe. If released from rest at the position shown, where the spring is unstretched, what speed will the collar have after moving 50 mm ? The spring constant is $2,000 \text{ N/m}$.

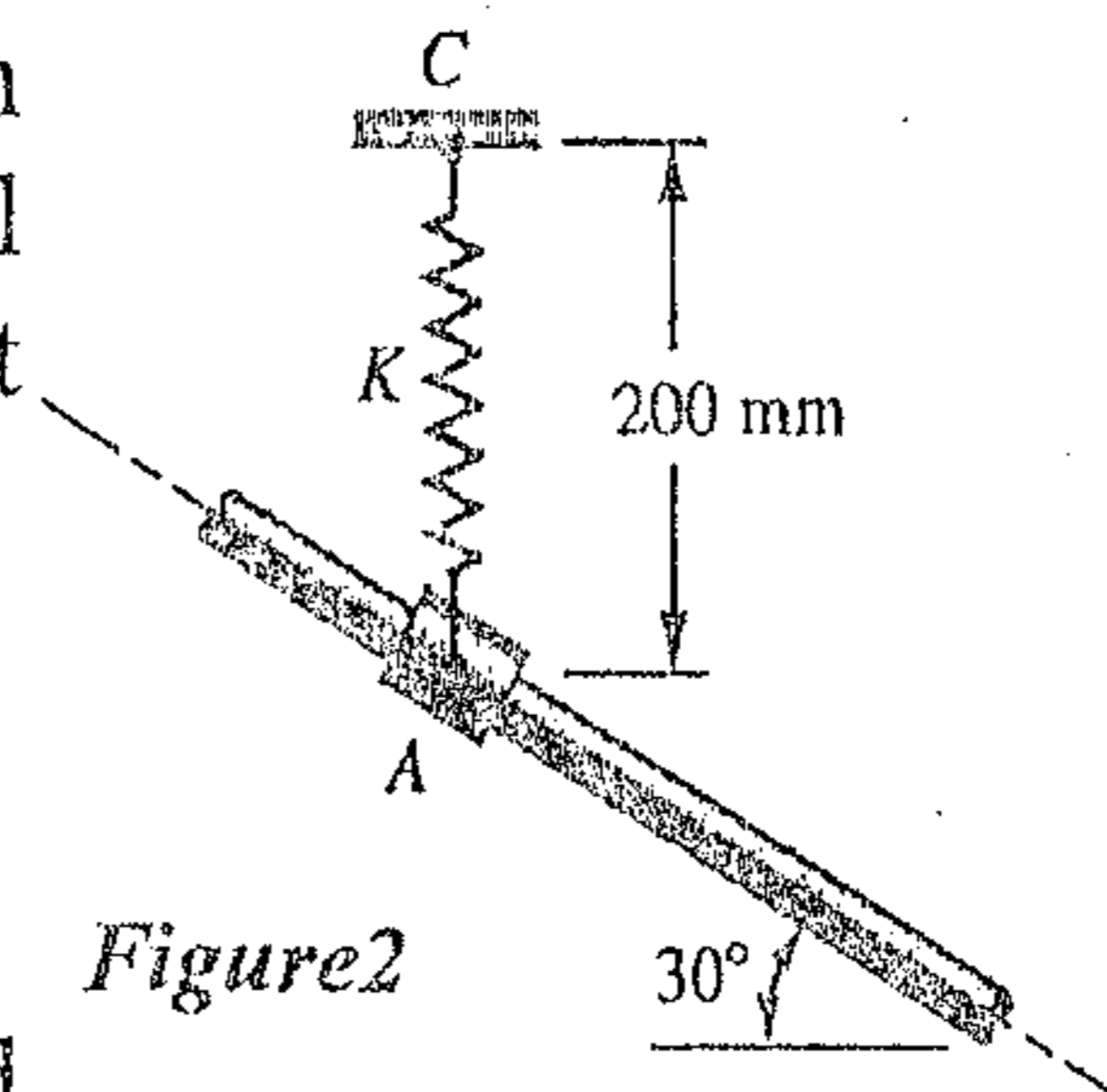

Figure 2

3. A disk of mass m and moment of inertia I is released (20%) from rest on an inclined surface (Figure 3). Assuming that it rolls, what is the velocity of the disk's center when it has moved a distance b ?

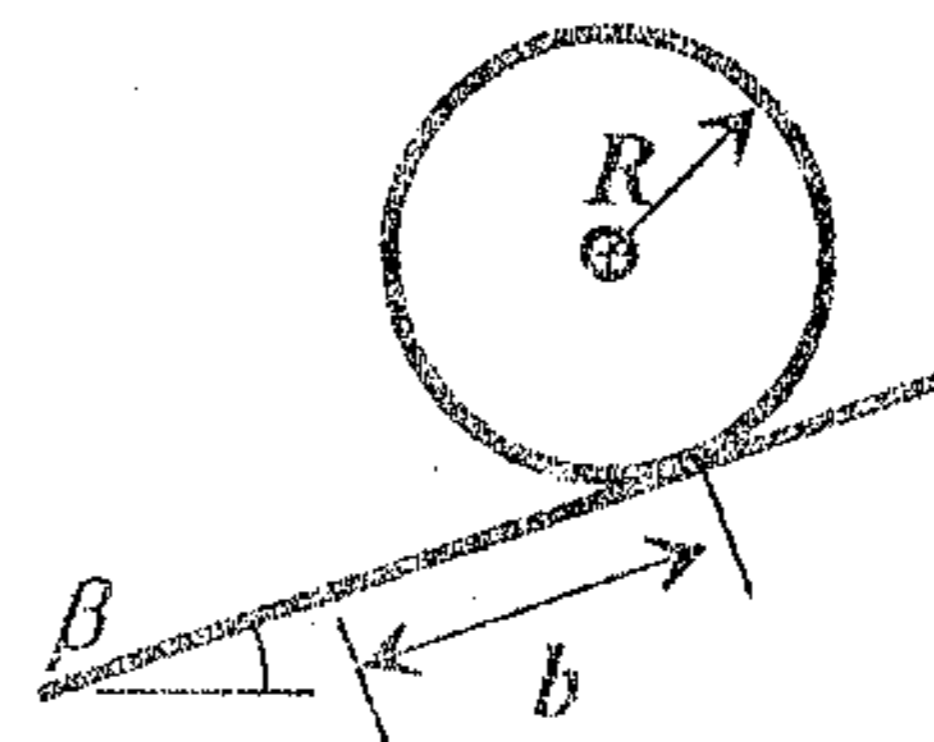

Figure 3

4. For the beam and loading shown in Figure 4, (20%)
 (a) determine the reaction at the roller support.
 (b) Draw the bending-moment diagram.
 (c) Determine the deflection at the midpoint C of the span.

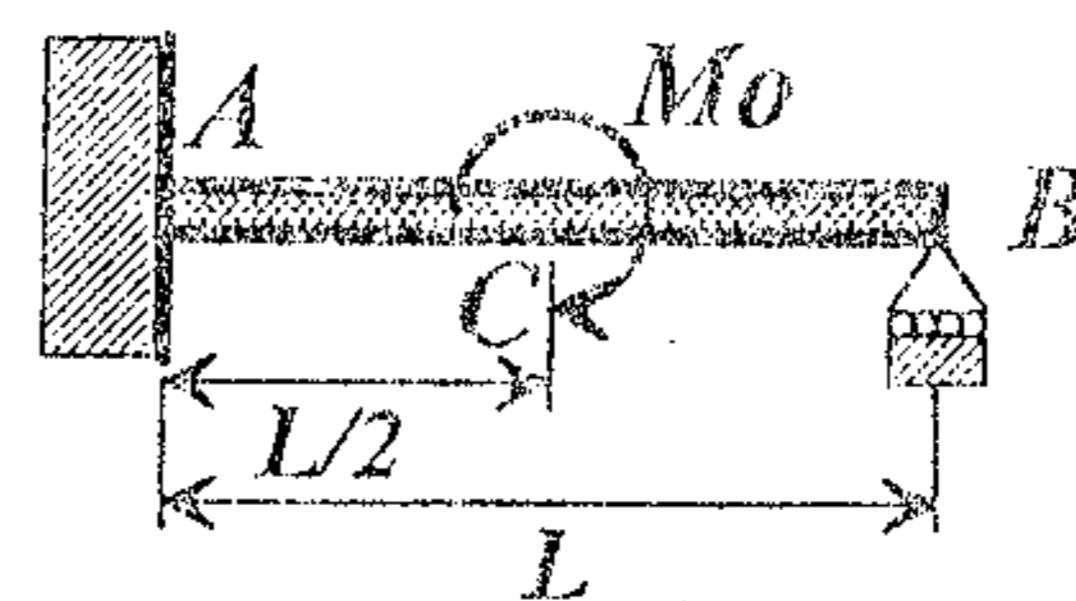

Figure 4

5. A composite beam having the cross-sectional dimensions (20%) shown in Figure 5 is subjected to a positive bending moment $M = 35000 \text{ in-lb}$. Calculate the maximum and minimum stresses in both materials of the beam assuming $E_1 = 1,000,000 \text{ psi}$ and $E_2 = 20,000,000 \text{ psi}$.

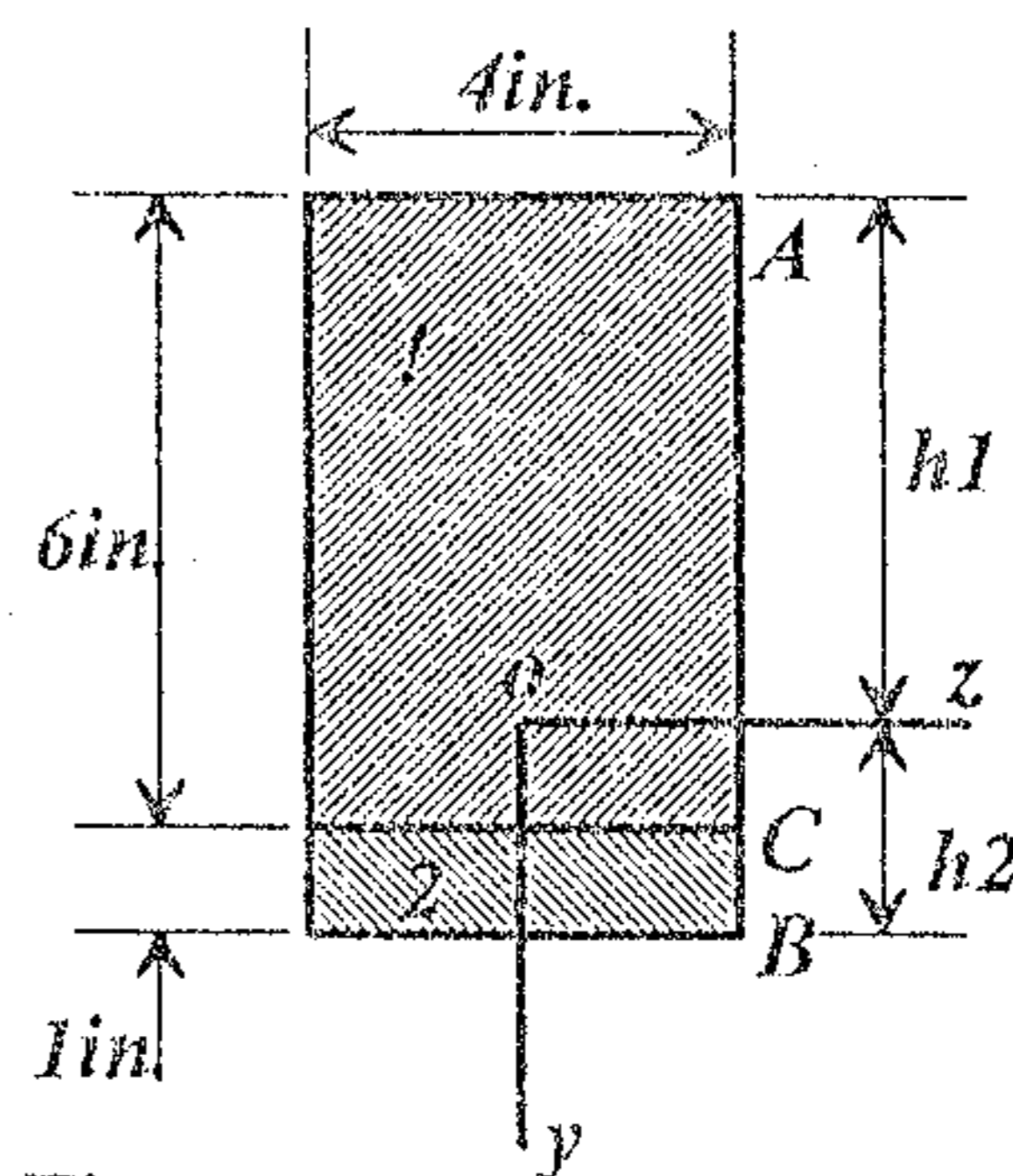

Figure 5